

VOLTA Powered Sliding Door Roller

Product Specifications

VOLTA SIZE LIMITATIONS

Refer to the relevant Door Technical Manual for full product limitations.

Panel Width

Single VOLTA Minimum:	900mm
Double VOLTA Minimum:	1200mm

Panel Weight

XO & XXO with Single VOLTA:	75kg to 150kg	ODFR: <10kg force
XO with Double VOLTA:	75kg to 250kg	ODFR: <18kg force
XXO with Double VOLTA:	150kg to 200kg	ODFR: <18kg force

Notes:

Glazing – VOLTA Rollers are not compatible with single glazed door panels

ODFR – To ensure optimal user experience, the peak force to initiate movement of the non-powered door should fall inside the Optimal Door Friction Range (O.D.F.R.). Door friction can be measured by attaching a luggage scale to the door handle and measuring how many kilograms of force are required to initiate movement out of the jamb. Measurements should be taken at all points of highest initiating force, typically the fully closed position and at the point of stacking.

Operation – The VOLTA system is designed to function with a minimum panel weight of 75kg. To test the door prior to glazing sufficient weight must be added.

Water Exposure – All components of the VOLTA system which are designed to be installed within 150mm of the finished floor level are sealed against water ingress and are capable of full submersion. All other components are installed within the frame of the system are not exposed to rain fall however are resistant to incidental water exposure. At 18VDC the VOLTA system is categorised as extra-low voltage which carries low risk of electrical shock.

VOLTA Powered Sliding Door Roller

Components - VOLTA Roller

Not To Scale

8800 and 8801
POWER ASSIST SINGLE ROLLER KIT
EACH

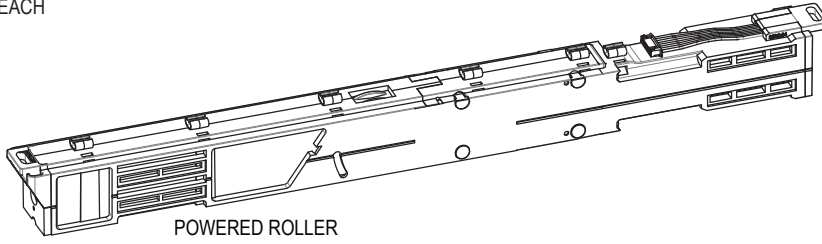

CONTROL BOX

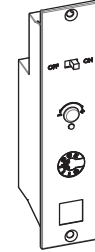

CHARGING BASE

BATTERY PACK

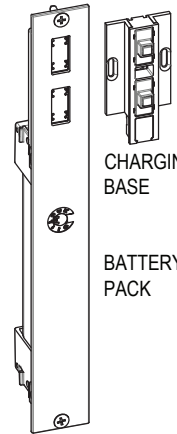

POWER ASSIST DOUBLE ROLLER KIT
EACH
(SPD05633)

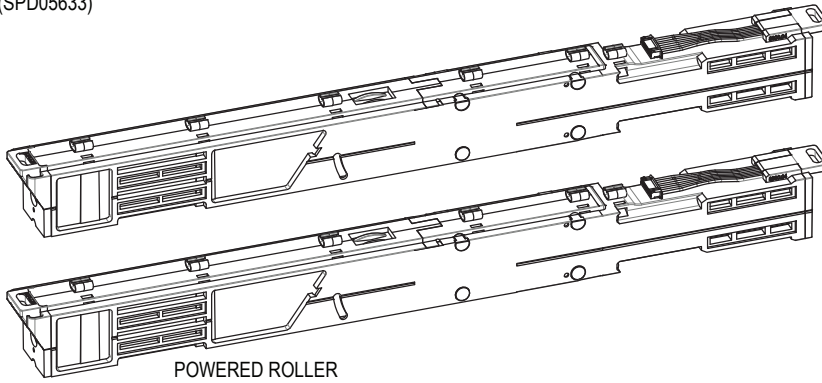

CONTROL BOX

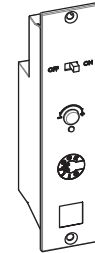

CHARGING BASE

BATTERY PACK

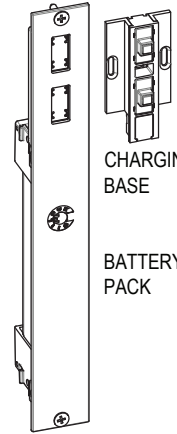

5801-101
CAPRICE HANDLE ADAPTOR SET
EACH

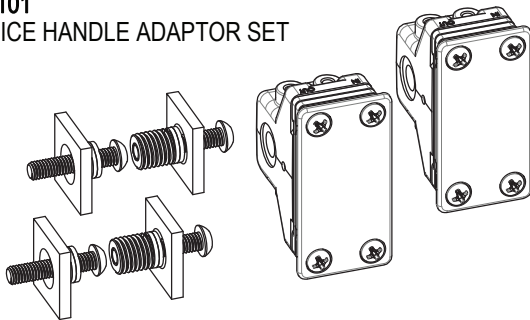

USE WITH CAPRICE PULL HANDLE KITS

5801-102
CAPRIO HANDLE ADAPTOR SET
EACH

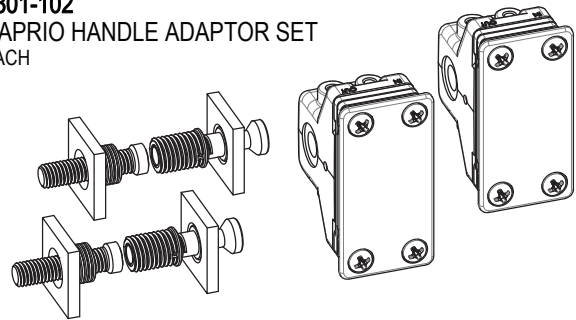

USE WITH CAPRICE OR 3541 BODY & CAPRIO 800mm PULL HANDLE

5801-103
ALT. HANDLE ADAPTOR SET
EACH

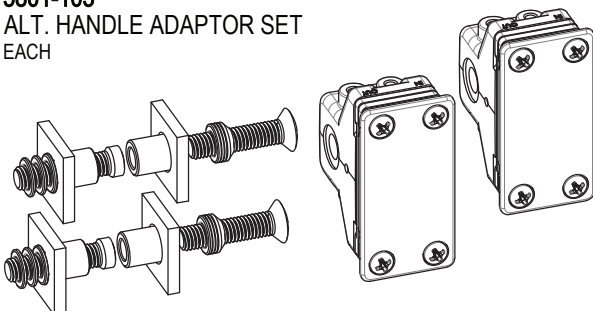

ALT. TO ABOVE KITS

VOLTA Powered Sliding Door Roller

Machining - Stiles for VOLTA Roller, Control Box & Battery Set

Scale 1:2

NOTE: NOT COMPATIBLE WITH SG STILES

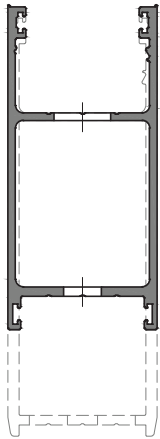

EP19607 . EP13547 .
MORTICE . WIDE LOCK STILES
ROLLER CONNECTOR CABLE HOLE

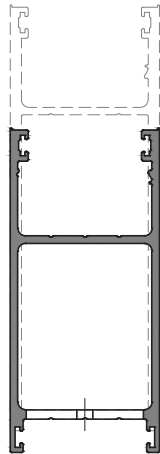

EP19607 . EP13547 .
MORTICE . WIDE LOCK STILES
CONTROL BOX

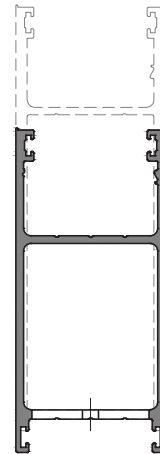

EP19607 . EP13547 .
MORTICE . WIDE LOCK STILES
BATTERY SET

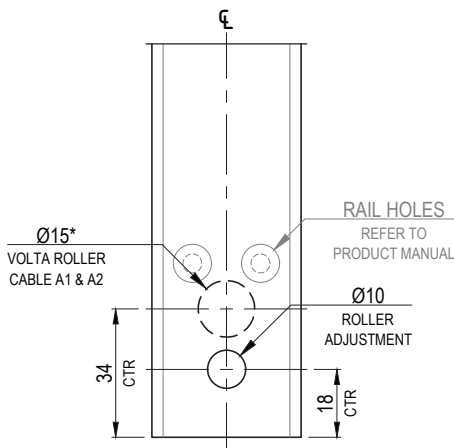

* HOLES MUST BE
DE-BURRED TO AVOID
DAMAGE TO THE CABLES

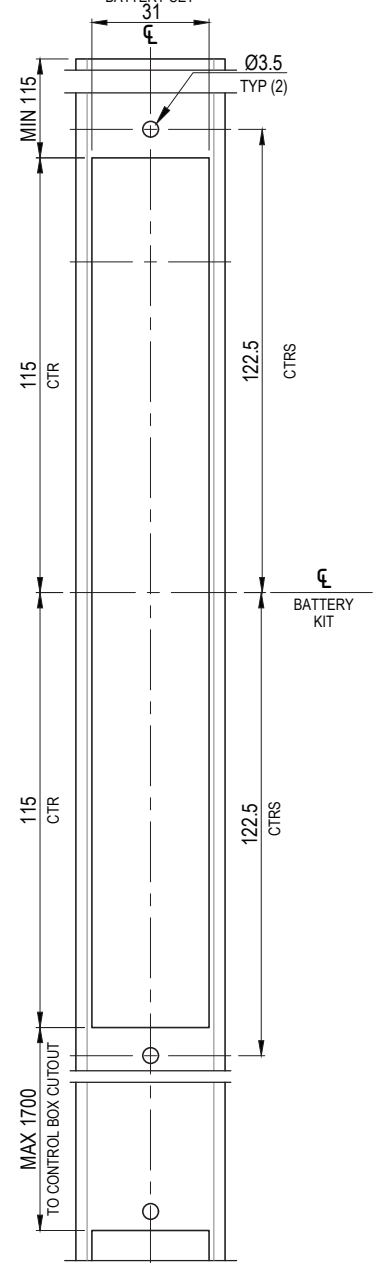
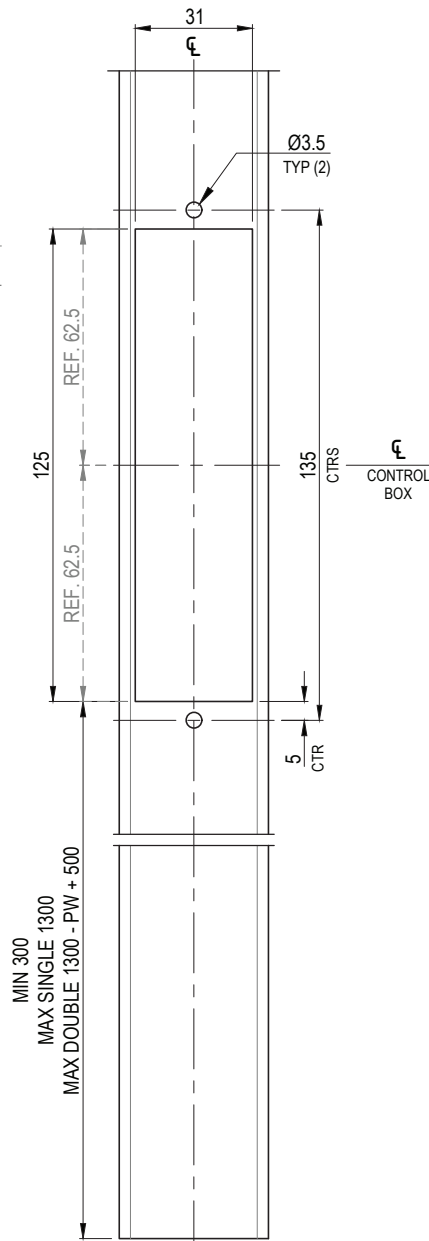
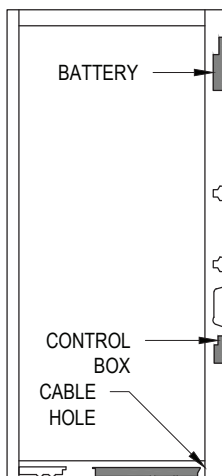

VOLTA Powered Sliding Door Roller

Machining - VOLTA Handle Adaptors & Roller

Scale 1:2

NOTE: NOT COMPATIBLE WITH SG STILES/RAILS

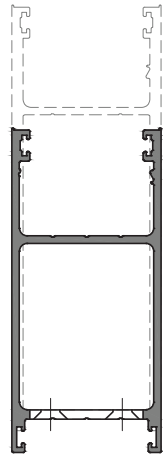

EP19607 . EP13547 .
MORTICE . WIDE LOCK STILES
PULL HANDLE ADAPTORS

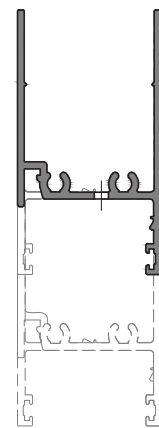
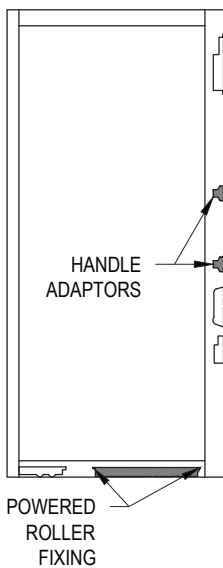
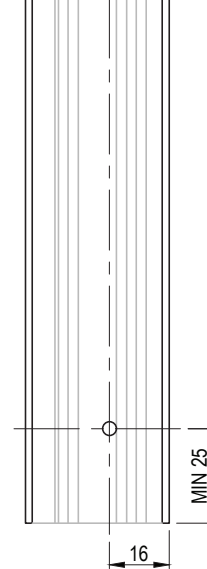
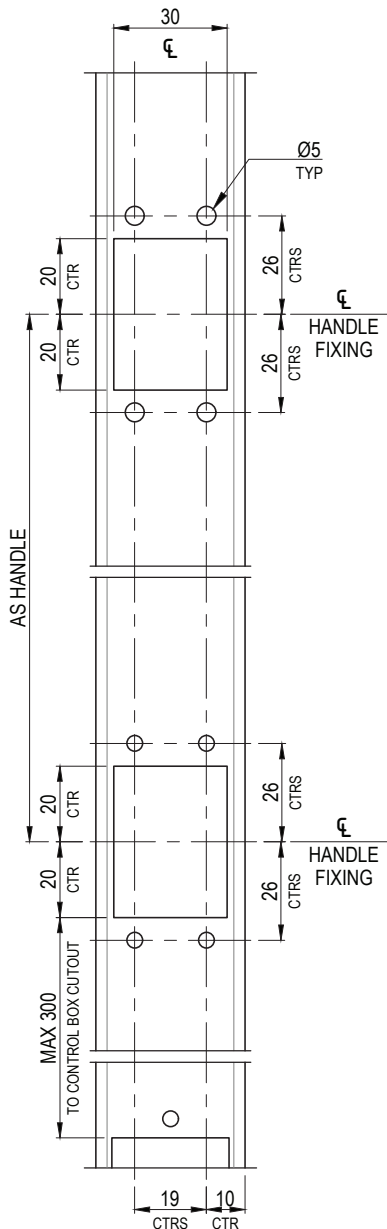
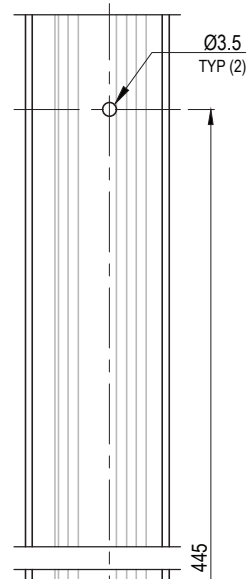

**VARIOUS
DG RAILS**
VOLTA ROLLER

IT IS RECOMMENDED THAT THE ROLLER HOLES ARE
DRILLED BEFORE ROLLER INSTALLATION TO HELP
AVOID DAMAGING POWER CABLES

VOLTA Powered Sliding Door Roller

Assembly - Volta Sliding Door Battery, Control Box & Rollers

Not To Scale

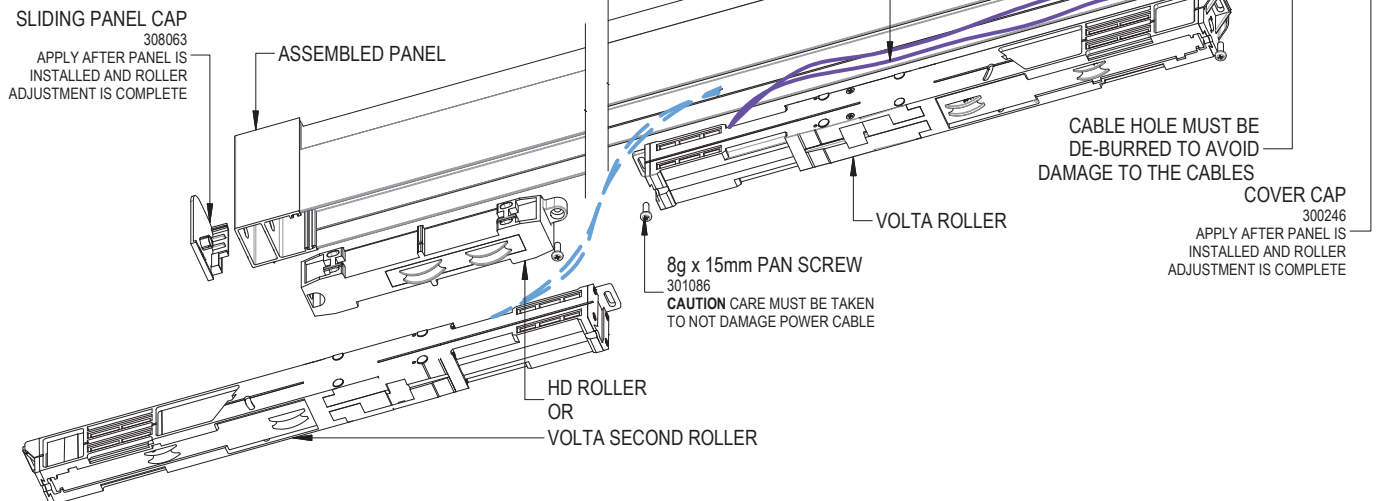
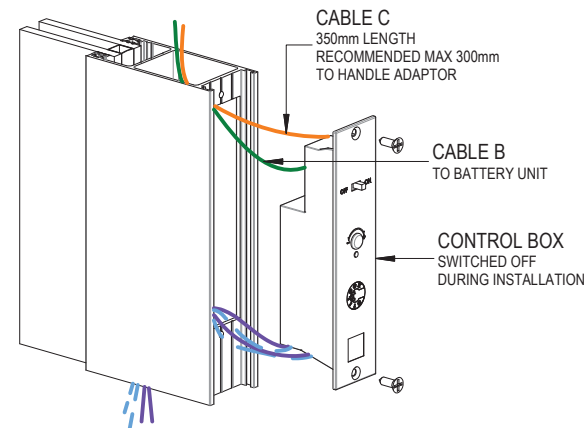
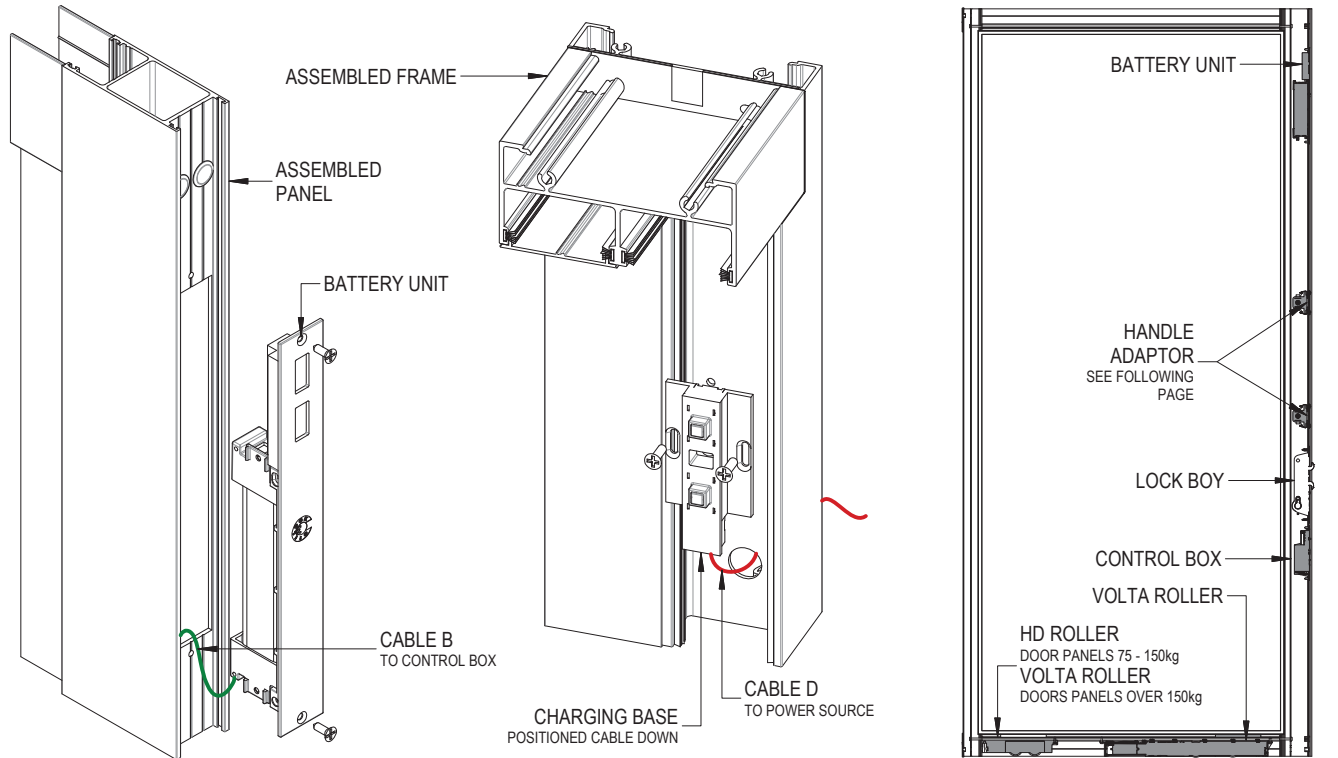

VOLTA Powered Sliding Door Roller

Assembly - VOLTA Handles

Not To Scale

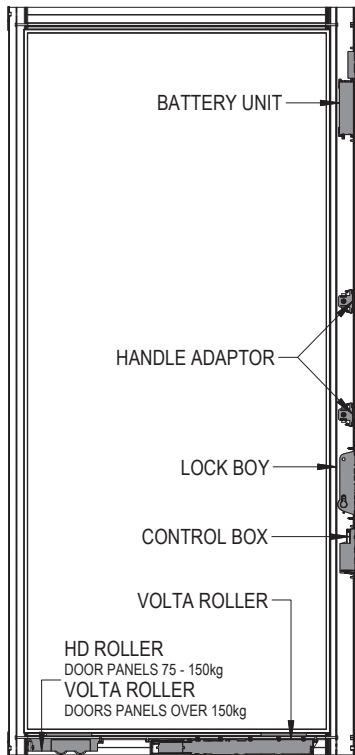

HANDLE ADAPTORS WITH CAPRIO PULL HANDLE

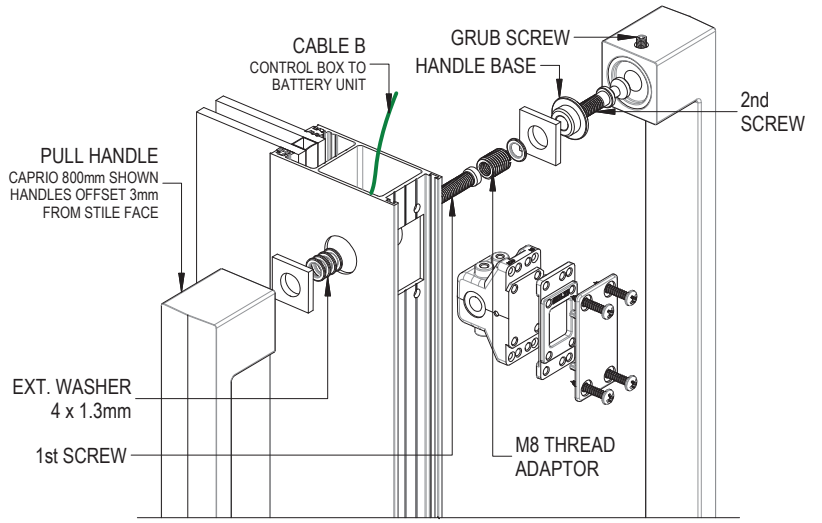

INT. WASHER
1 x 1.3mm

HANDLE ADAPTORS WITH CAPRICE PULL HANDLE

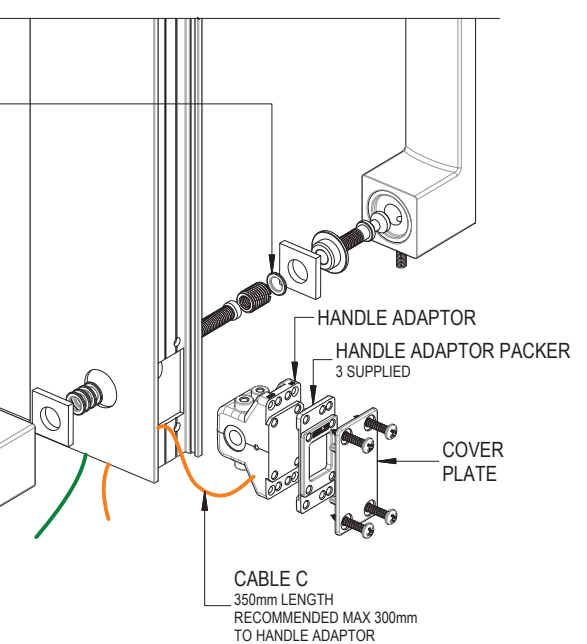
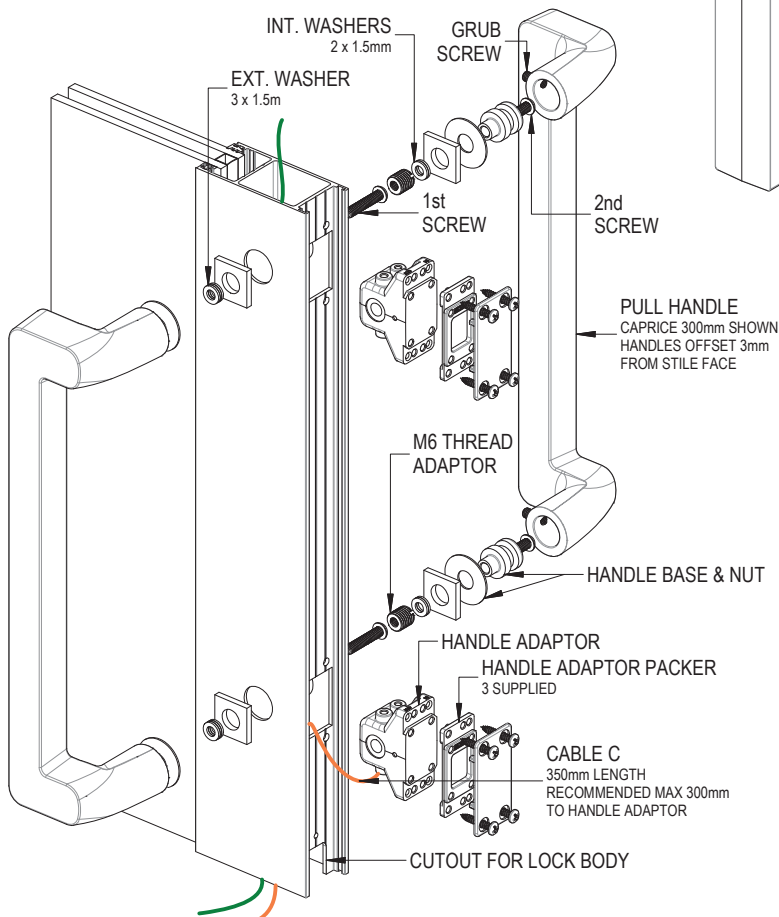

1. INSERT HANDLE ADAPTOR AND THEN HANDLE ADAPTOR PACKERS (IF REQUIRED) INTO STILE THEN FIX THE COVER PLATE
2. INSERT 1ST HANDLE SCREW FROM INSIDE THROUGH STILE/HANDLE ADAPTOR AND WASHERS INTO OUTSIDE HANDLE
3. INSERT THREAD ADAPTOR (IF REQUIRED)
4. INSERT 2ND HANDLE SCREW THROUGH HANDLE BASE & WASHERS INTO HANDLE ADAPTOR
5. POSITION HANDLE & TIGHTEN GRUB SCREWS