



Our AWA membership is your  
guarantee of performance

# TITAN The Be-All and End-All Of Bi-Fold Systems



## Installation Instructions

HD System 18.5mm Offset -  
16mm Bearing Guide Wheel



t. 03 9703 1006

e. [sales@ciilock.com](mailto:sales@ciilock.com)

[www.ciilock.com](http://www.ciilock.com)

# TITAN HD BI-FOLD HARDWARE

## Installation Instructions

Applies to:

18.5mm offset, 16mm bearing bottom guide wheel

P.O. Box 5060, Hallam  
VIC 3803, Australia  
www.ciilock.com - info@ciilock.com

### Step 1:

Fabricate frame taking into account the following recommended information on panel gap clearance

- . Top pivot
- . Quick Fix Pin
- . Hinge
- . Bottom pivot carrier
- . Hinge

- . Wall pivot set
- . Pivot hinge leaf

- . Hinge x2
- . Hinge handle

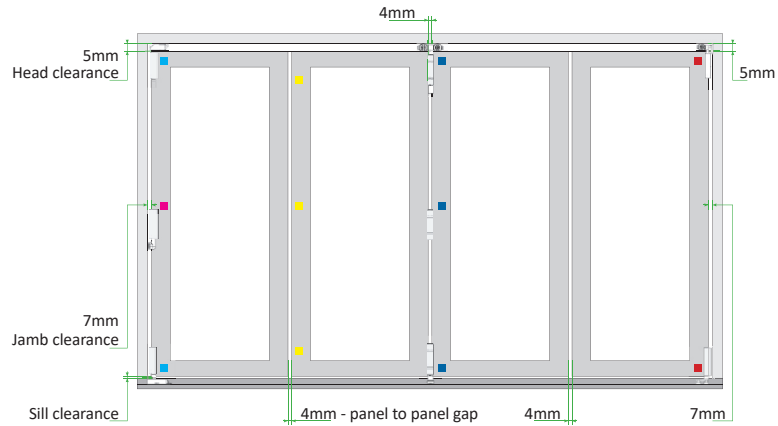

- . Top end carrier
- . Quick Fix Pin
- . Hinge
- . Bottom end carrier
- . Hinge

- . Top intermediate carrier
- . Quick Fix Pin
- . Hinge
- . Hinge
- . Bottom intermediate carrier
- . Hinge

### Step 2:

Cavity, track and channel guide.  
(Recommended guide)

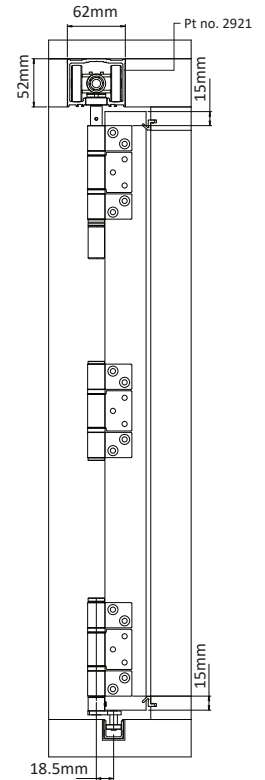
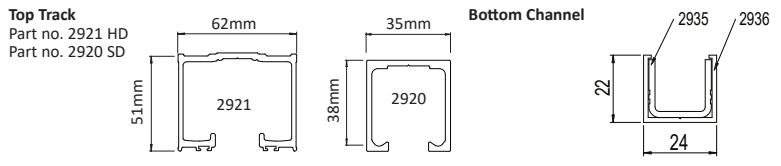

### Step 3:

Door size calculation and hinge guide.  
(Recommended guide)

Index	Meaning
$G_{JP}$	Jamb to panel gap (door closed)
$G_{PP}$	Panel to panel gap (door closed)
$L_o$	Opening width
$N$	Total number of panels
$W$	Panel Width
$G_H$	Head clearance
$G_S$	Sill clearance
$H_o$	Opening height
$H$	Panel height

Recommended panel gaps are in step 1.

#### Width Calculation (all panels equal width)

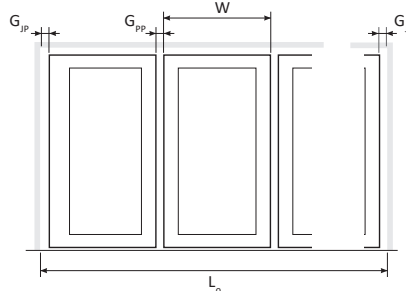

**Formula**  

$$W(\text{mm}) = \frac{L_o - (2 \times G_{JP}) - (N - 1) \times G_{PP}}{N} \text{ (mm)}$$

#### Height Calculation

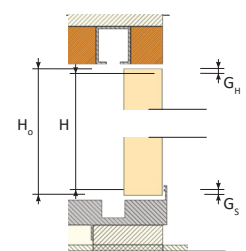

**Formula**  

$$H = H_o - G_H - G_S \text{ (mm)}$$

#### General Recommendation

Height/mm	No. of hinges
2000	Recommended 3 hinges min
2400	Recommended 4 hinges min

**Step 4:**  
Hinge selection.

**Centerline | Offset Hinge Outline:**

The hinge configurations are entirely dependent on the number of panels used on any one stack of panels. This is so when stacked, the panels can sit perpendicular to the track centerline and stack efficiently. The hinge set configurations will change depending on a number of factors and is determined by the number of panels. Consequently the number of panels will determine the number of intermediate carrier sets and if an end carrier set is required.

**Note** - an access panel (if required) is only possible for odd numbered stack configurations, unless used as a single door at one end. We will refer to the hinge on the opposite side of the panel to the carrier or pivot set as the outer hinge.

Centerline and offset hinges.

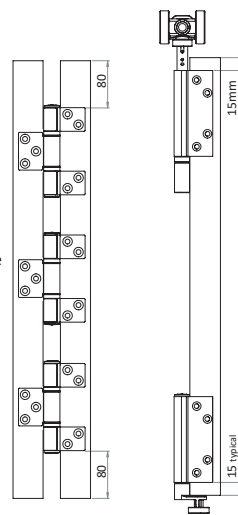

**Centerline Hinge**

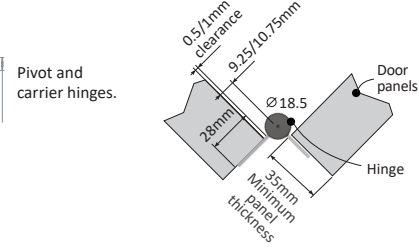

**Offset Hinge**

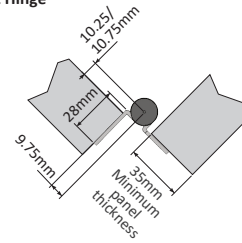

**Guide for selecting outer hinges:**  
**2 panels** only will require a Centerline hinge set:

**3 or more odd numbered panels** will require the first outer hinge set to be offset. Subsequent hinge sets will be centerline.

**4 panels** will require two offset hinge sets.

**6 or more even panels** will require the first and last outer hinge sets to be offset, however any hinge sets in between will need to be centerline.

**Step 5:**

Install seals in doors as per manufacturers specifications. (Example shown)

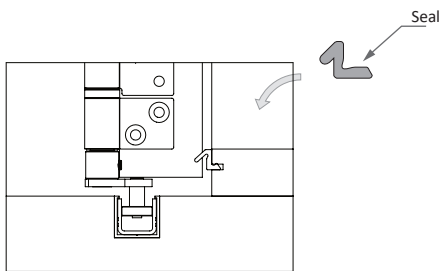

**Step 6:**

6. Cut top and bottom track to desired length to match frame. (Example shown)

**Titan HD Top Track**

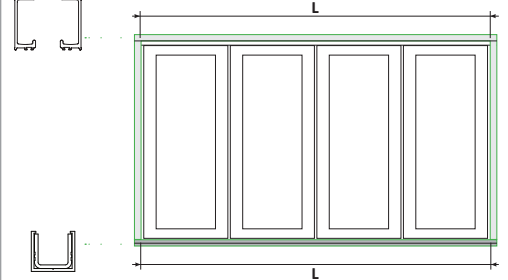

**Titan HD Bottom Channel**

**Step 7:**

Create cutout for top pivot mount.

a. Mark, punch and drill for cutout.

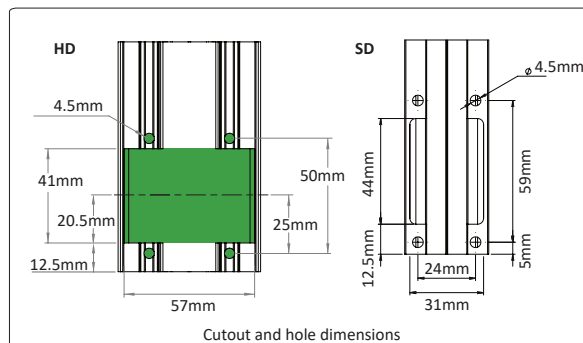
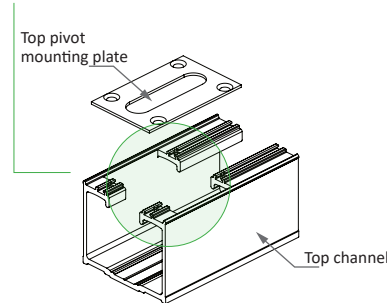

b. Check that mounting plate fits onto extrusion. Do not install top pivot yet.

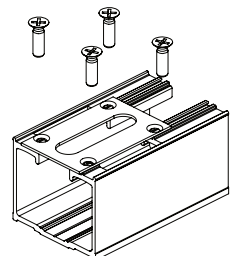

**Step 8:**

Install top and bottom tracks into the frame, fixing at the specified points (minimum) using the specified fasteners (minimum).

**Track Fixing Points**

Fix track with minimum 10g screws (timber frame).

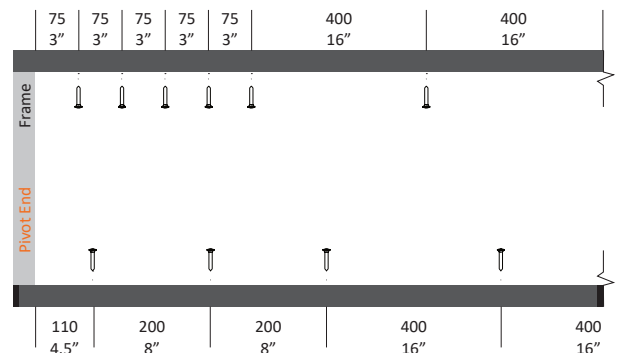
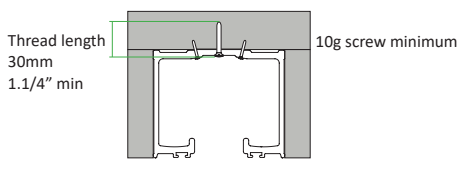

**Step 9:**

Install bottom pivot set mount.

a. Insert into bottom track.

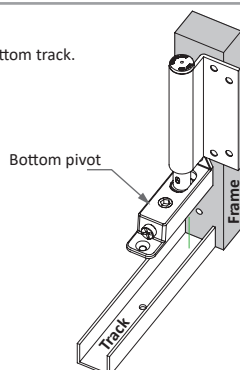

b. Fix bottom pivot to track and frame.

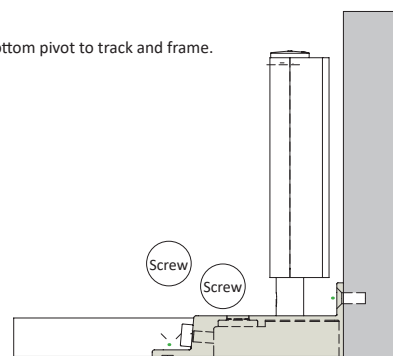

**Step 10:**  
Install hinges onto doors prior to mounting panels onto frame.

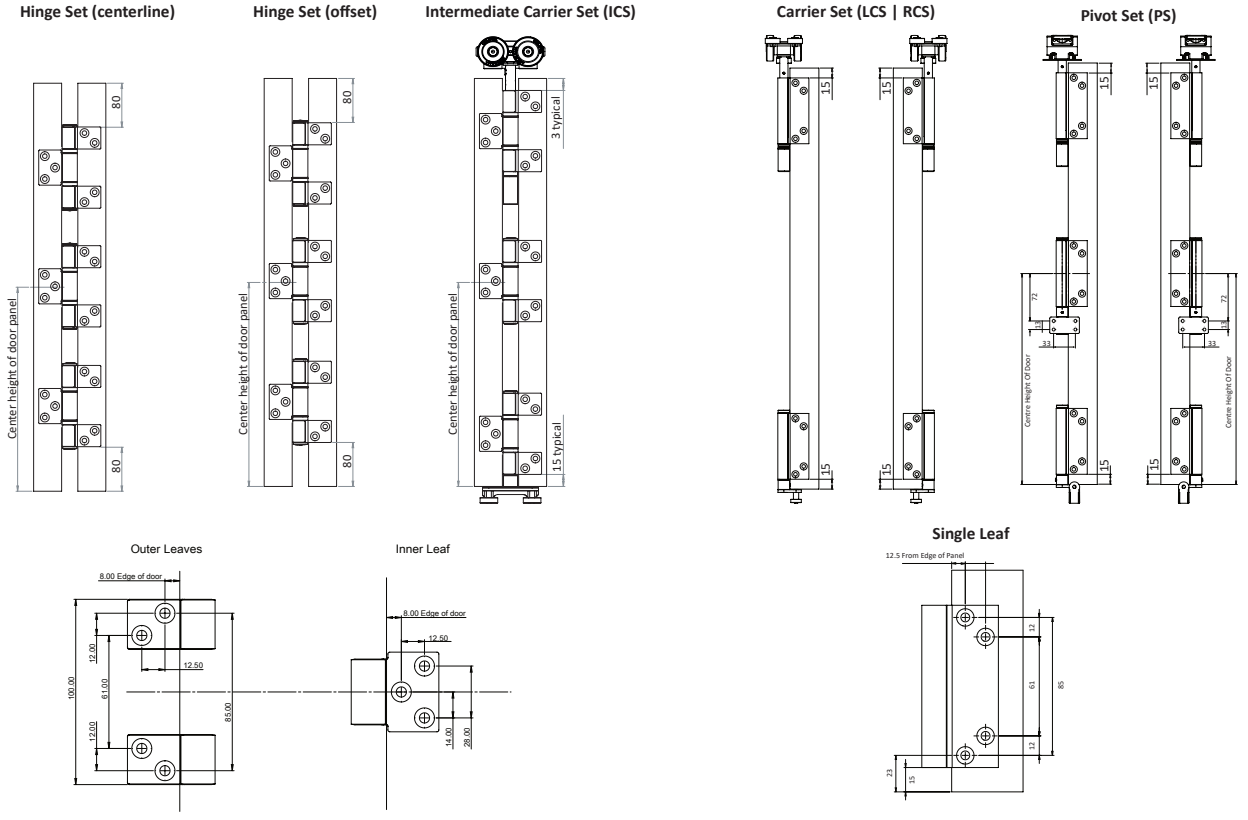

**Step 11:**  
Install hinges.

Mark and drill for hinges using hinge or template.

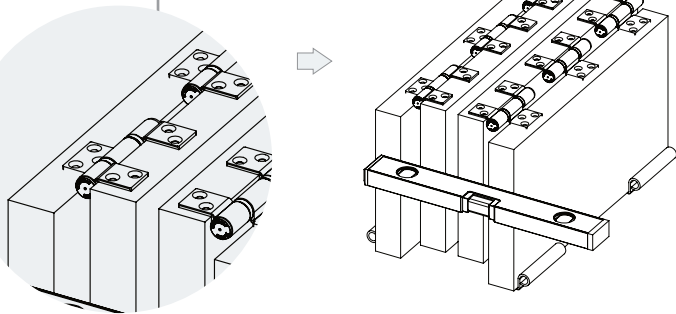

**Step 12:**

12. Install carrier and guides.

Mark and drill for hinges using hinge or template.

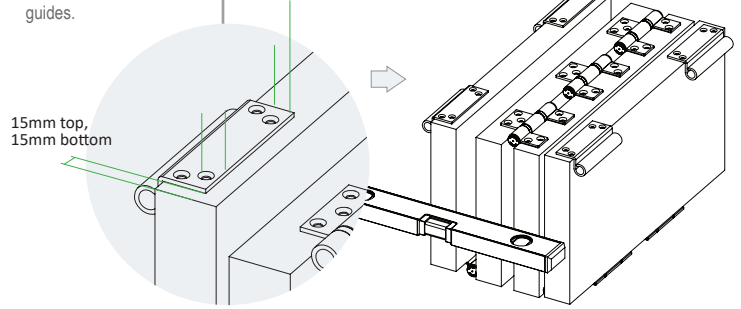

**Step 13:**  
Install frame.

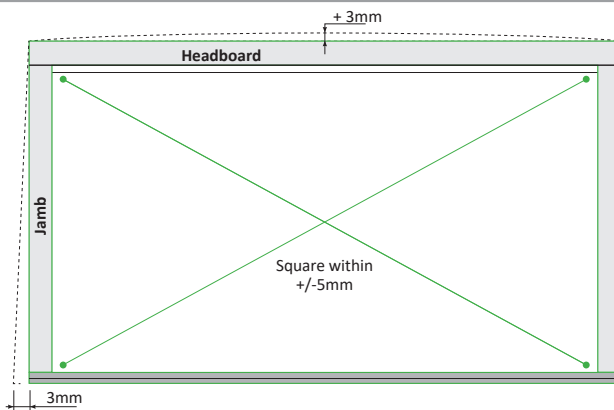

**Step 14:**

Install top carrier sets in top extrusion.  
(Example shown)

Order of installation should be as follows (left and right opening) - end carrier, intermediate carrier and pivot set last.

Note: pivot set and hinge pins will not be installed until later.

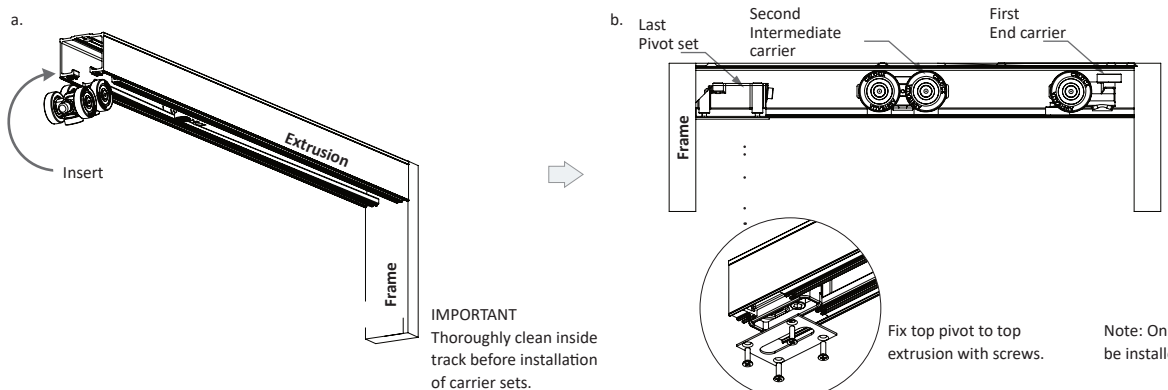

**IMPORTANT**  
Thoroughly clean inside track before installation of carrier sets.

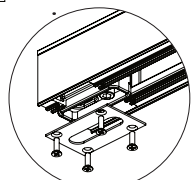

Fix top pivot to top extrusion with screws.

Note: Only carriers to be installed not pins.

**Step 15:**  
Install door panels onto frame.

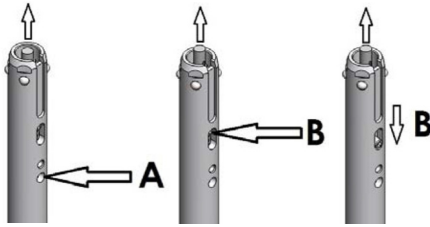

a. Insert a 3mm diameter steel pin (or similar) into hole 'A' to push and hold up the internal plastic pin. When inserted, ensure the 3mm steel pin is under the end of the plastic pin. Insert a 2mm diameter steel pin (or similar) into the grub screw 'B' and pull down the grub screw. You will feel a click and the pin is reset.

Alternatively you can use the Titan Pin Reset Tool as shown on the right.

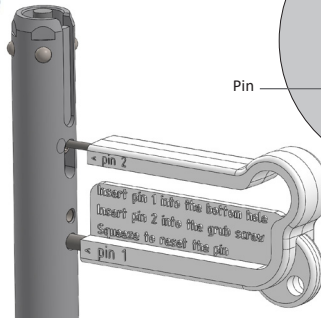

b. Position and align with the carrier slot. Insert pin into carrier. Pin will hold in place.

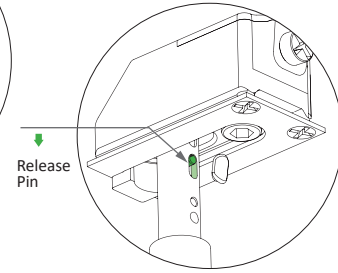
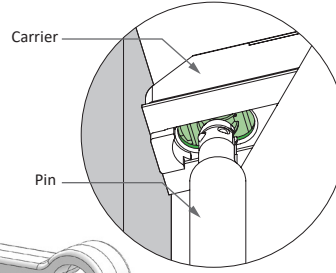

c. To release pin - remove plastic cover cap and pull the release pin down. Pin will disengage.

**Panel installation**

a. Bring pivot panel (panel 1) to top and bottom pivot set and attach. Hinge set attached to panel.

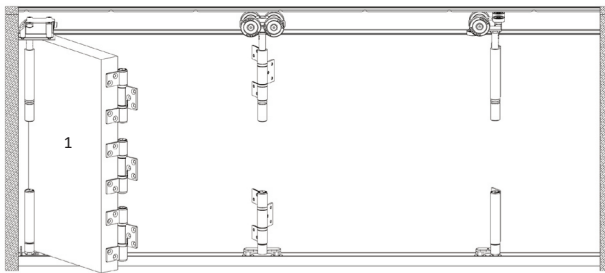

d. Bring second intermediate panel (panel 3) to the intermediate carrier/ guides with hinge set attached. Bring end panel (panel 4) to hinge set.

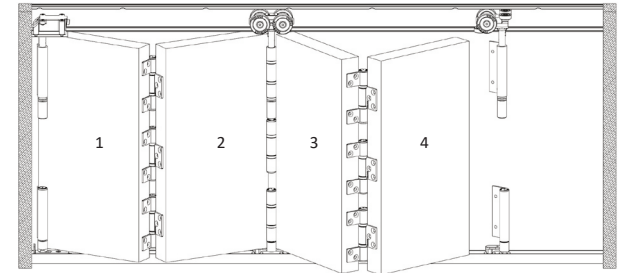

b. Bring first intermediate panel (panel 2) to pivot panel. Middle hinge of intermediate set attached.

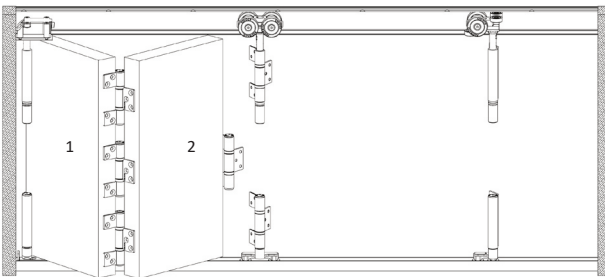

e. Fix end panel to end carriers/ guides.

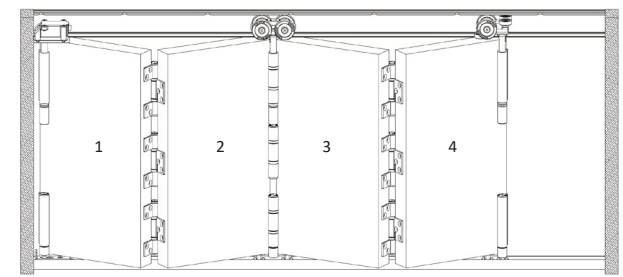

c. Fix intermediate hangers to intermediate panel (panel 2). Attach intermediate carrier/ guide to intermediate panel (panel 2).

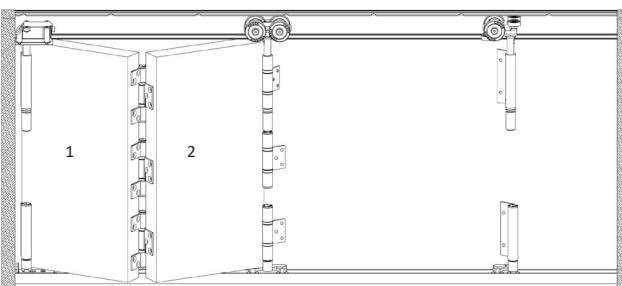

f. Close all panels and ensure proper operation.

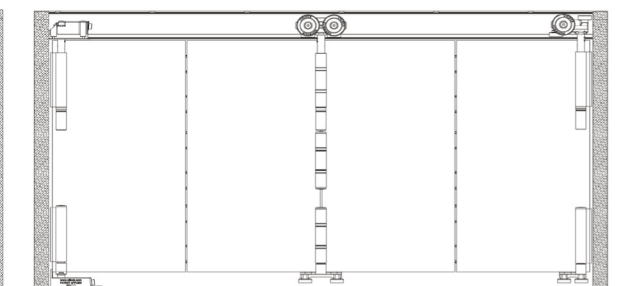

**Step 16:**  
Wall pivot installation (optional).

Wall pivot sets are to be installed at the center of the door panel.

a. Install hinge onto door panel. Hinge leaf to be center of top and bottom pivot hinge leaf.

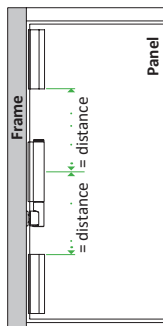

b. Mark out location of mounting plate on frame. Open panel and fix mounting plate to frame.

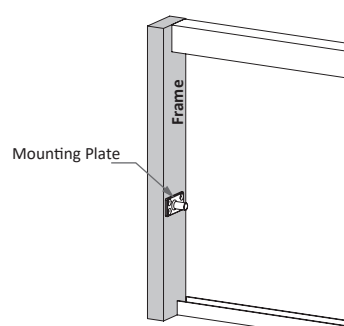

c. Close panel ensuring mounting plate pin inserts into wall pivot correctly.

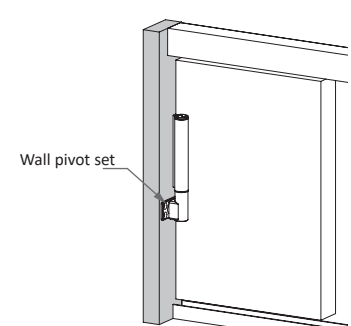

**Step 17:**

Panel adjustment.  
Adjust top and bottom pivot until all door panels are level and correct clearance at both ends of door assembly.

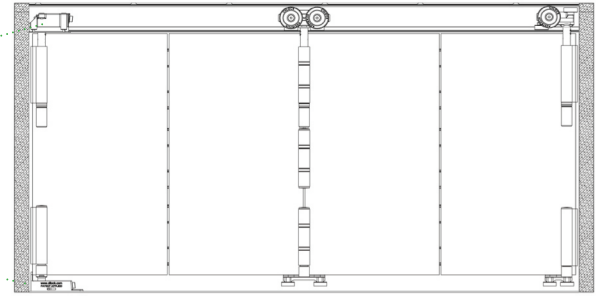
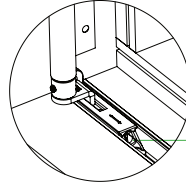
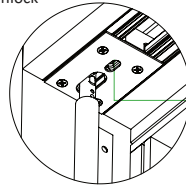
**Lock and Unlock****Step 18:**

18a. Panel adjustment.  
Adjust top pins using hex key until correct height is achieved.

18b. Lock off pin by tightening left hand screws with a phillips screwdriver.

18c. Open all doors and check for correct operation. Check top and bottom tracks are clean.

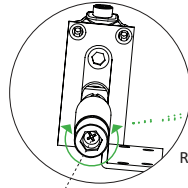
**Vertical Adjustment**

Left hand screw

Rotate to adjust

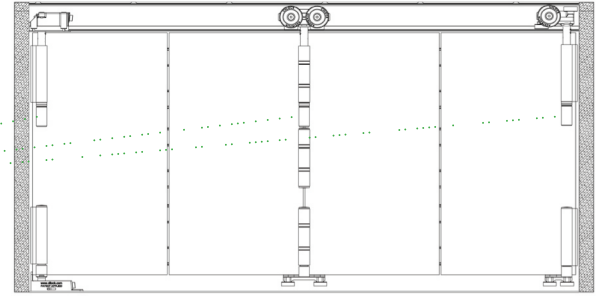
**Step 19:**

System overview.

Titan SD hardware system installation overview.

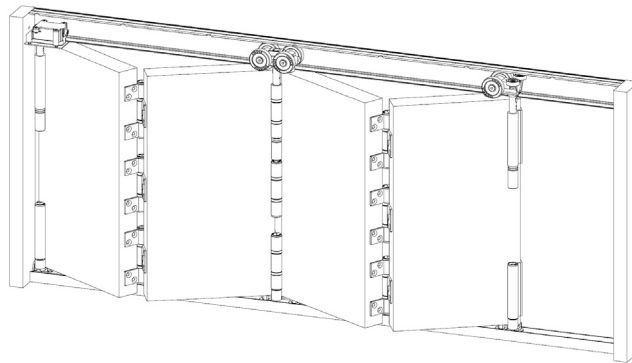
**System Overview****CARE AND MAINTENANCE**

In order for the Titan hardware components to continuously perform correctly and meet the requirements of the product warranty, the following care and maintenance must be undertaken:

**INSPECTION AND ADJUSTMENT:** The structure supporting the door may change over time so periodic inspection and necessary adjustment of all hardware fasteners and adjustment components must be made. We recommend a periodic inspection of at least every 6 months.

**CLEANING:** Regularly clean/wash (with soap or mild detergent) all exposed components especially stainless steel components that will still show signs of surface corrosion in coastal and highly corrosive environments despite being stainless steel. Avoid using products that may contain solvents, acidic or abrasive substances i.e. cleaning products, as it can impair and blemish the finish of the product. After cleaning/washing, lubricate all hinges with a high performance silicon based lubricant. We recommend using an aerosol can version with spraying tube attached to the nozzle so that deep penetration is achieved. Coat all exposed surfaces with a surface protectant to reduce the possibility of corrosion in the future.

**Stainless Steel Hinges** - These can be cleaned with a product specifically designed to clean and protect stainless steel. Ensure only the stainless steel components are exposed to this type of cleaning product.

Regularly clear all debris and clean both top and bottom tracks so that all guide wheels are running on a smooth and clear surface.

**LUBRICATION:** Regularly lubricate all hinges using a high performance silicon based lubricant. We recommend using an aerosol can version with spraying tube attached to the nozzle so that deep penetration is achieved.